

The wheel chair accessible “Dolphin” bubbler by Parkequip has been designed to meet the needs of all people including those with varying degrees of disabilities.

There are no bowls or drains to clog, so maintenance costs normally associated with bubblers have now been eliminated by our unique approach to handling water.

- Sleek Design
- Wheel Chair Accessible
- Low Maintenance
- No drains or bowls to clean
- Graffiti Resistant
- Available in a range of stone finishes
  - Sandstone
  - Marble
  - Millstone

CONTROL FOUNTAIN

- Single Combination Press Button Fountain Head



*“Another Quality Australian Made product from Parkequip”*

# Technical Specifications

## DOLPHIN BUBBLER

## MODEL MAB 001

### MATERIAL

High Density Polyethylene Plastic  
compoll LL6488, UV stabilised plastic

### ULTRAVIOLET STABILITY

Cotene compounded polyethylene colours contain an excellent UV additive package of UV-8, which is designed to handle the harsh UV conditions in Australia

### FINISH EFFECTS

Sandstone  
Marble  
Millstone

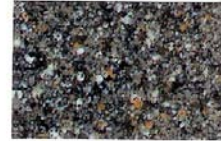

**Millstone** 867



**Sandstone** 927



**Marble** 251

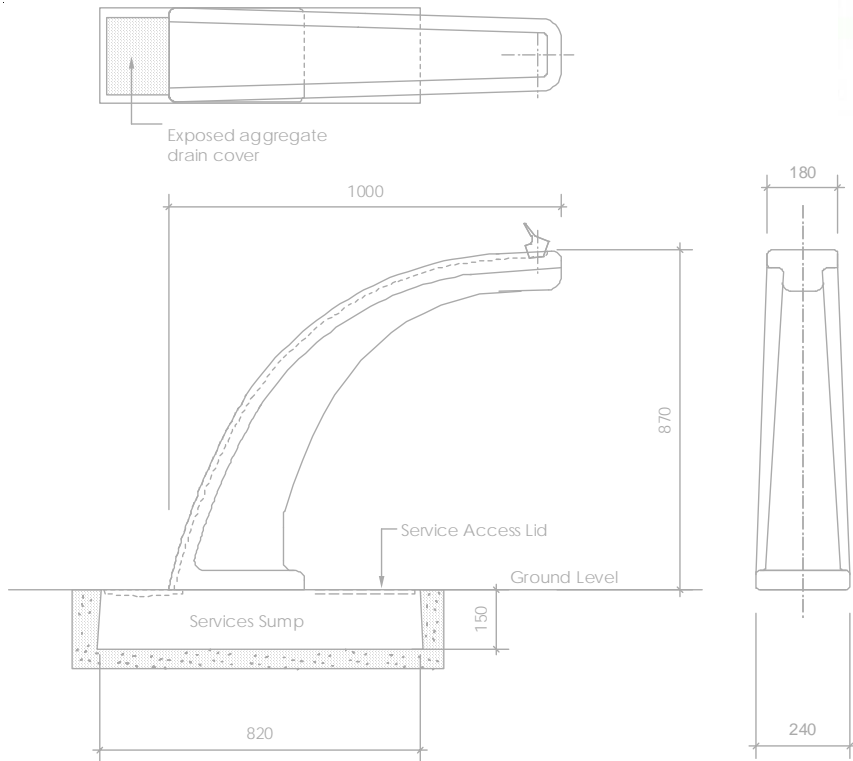

Copyright: All designs remain the intellectual property of Parkequip Pty Ltd

## PARKEQUIP PTY LTD

PO Box 7140 WETHERILL PARK DC NSW 1851  
Ph 02 9725 5604 Fax 02 9725 4420

ABN 86 088 184 927

www.parkequip.co.au  
Email: info@parkequip.com.au